

## The feasibility of using portable X-Ray radiography for the examination of the technology and the condition of a metals collection housed in the Museum of Ancient Messene, Greece

M. Giannoulaki<sup>1,3</sup>, V. Argyropoulos<sup>1\*</sup>, Th. Panou<sup>1</sup>, A. Moundrea-Agrafioti<sup>3</sup> and P. Themelis<sup>4</sup>

1. Department of Conservation of Antiquities & Works of Art, Technological Educational Institution of Athens, Ag. Spyridonos, Aigaleo, Greece 12210 [bessie@teiath.gr](mailto:bessie@teiath.gr)

2. Department of Radiology, Technological Educational Institution of Athens, Ag. Spyridonos, Aigaleo, Greece 12210 [thpanou@teiath.gr](mailto:thpanou@teiath.gr)

3. Department of History, Archaeology and Social Anthropology, University of Thessaly, Argonauton-Fillelinon, Volos 38221, Greece

4. Society of Messenian Archaeological Studies, 33 Psaromilingou Str., 105 53 Athens, Greece

Most museums in Greece with metals collections cannot undertake the necessary examination of their objects by X-Ray Radiography, because there are limited funds to purchase such an in-house system, and the laws for the management of cultural heritage in Greece does not allow for removal of museum objects for such analyses without permit, which is often difficult to obtain. Under the initiative of the European 6<sup>th</sup> Framework funded project PROMET, the TEI of Athens set up a portable X-Ray Radiographic unit to examine the collection of iron and copper alloy objects from the Museum of Ancient Messene in Greece *in-situ*.

The collection includes different types of artifacts from copper and iron alloys (weapons, tools-instruments, accessories of doors and furniture, decorative artifacts, vessels, figurines-statuettes). Around 1000 objects were examined using the portable X-Ray radiographic system, in order to distinguish the characteristic technological features and to survey the condition of the artifacts.

The paper describes the feasibility of using such a portable system to examine large archaeological collections of metal objects, which is considered a necessary first-step before undertaking conservation treatment. Furthermore, the interesting features and condition of the museum metal artifacts in Ancient Messene are described. For example, the iron artifacts exhibit clear signs of active corrosion, but it is not always easy to determine the exact amount of remaining metal or the initial shape and form of the artifact. Artifacts made by copper alloys - were either cast or hammered or both, but sometimes it was difficult to distinguish these two manufacturing techniques by visual inspection alone, especially for thin and small objects. Also, some of the artifacts exhibit surface decoration and features, not always visible, due to the presence of thick corrosion layers. An interesting example was the case of a copper alloy shield from the end of 4<sup>th</sup>-beginning of 3<sup>rd</sup> c. B.C., where the X-ray radiographic system identified a decorative-motif and epigraphy on the surface, which was not clearly visible prior to the examination with the system.

The first step included the purchase of a used Military Tubestand X-Ray Apparatus, Mobile-Portable, manufactured by Picker X-Ray Corp. The portable X-Ray Radiography unit was purchased for a small cost, around 1.700 Euros. The system was transferred by car to the museum of Ancient Messene for analyses of the objects. The results in terms of determining the amount of metal remaining and impression of details of the objects were very good, but a problem was the long working time when the films had to be developed at a local hospital with the necessary facilities.

Thus, it was considered necessary to make the radiography system more feasible for use *in-situ*, by also developing the films *in-situ*, which involved the purchase of a portable film processor Curix 60 manufactured by Agfa. The system exhibits the following advantages: top quality, low operating costs, simplicity of use, and ease of servicing and environmental protection. The film processor cost around 4.700 Euros.

Examining over 1000 objects of different shapes and dimensions in two days required operating the system 8 hours each day. For the examination of these objects, 85 radiographic films

(dimensions 24X30 and 35X35), 8 bottles of developer liquid and 5 bottles of fixer liquid were used. The total cost of the supplies was around 400 Euros.

The portable radiography system worked well in examining all the metal objects from Ancient Messene, because it could be applied easily *in-situ* in the storage room of the museum. The films could also be easily developed with the portable film processor in the bathroom near the storage room. The examination was considered essential so that the conservator(s) can make the necessary decisions on how to clean and/or stabilize the metal artifacts.

*Keywords:* metal collection, Ancient Messene, copper and iron alloys, portable X-ray radiography, film processor.

## 1. INTRODUCTION

The collection of metal artifacts from the ancient city of Messene is being studied to determine the problems and needs of a typical archaeological collection in Greece under the auspices of the EC program PROMET. The main objective of the project is to develop a conservation strategy to preserve large metals collections housed in an uncontrolled museum environment. Such a strategy requires the application of scientific techniques *in-situ*, in order to identify the value and condition of each artifact housed in the museum, so that value-judgements can be taken on which objects are in urgent need of treatment, would benefit from treatment or do not require any treatment. However, for such a strategy to be viable for museums, it must be economical to apply. The paper describes one aspect of our approach to apply such a strategy by using X-ray Radiographic analysis to examine an entire collection of metal artifacts, quickly and economically.

The collection of ancient Messene includes different types of artifacts from copper and iron alloys (weapons, tools-instruments, accessories of doors and furniture, decorative artifacts, vessels, figurines-statuettes). A small number is exhibited in the museum of Ancient Messene and the rest of the collection is kept in the storage facilities of the museum.

The problems one has to deal with are the following:

- The objects are catalogued according to their excavation context, but they are not separated according to typological or technological groups. So all the relevant information, concerning the representative types, the distribution frequencies and the technological features of the whole collection cannot be easily distinguished. Thus, it is difficult to appreciate the value of the whole collection in terms of ancient metallurgical techniques.
- The condition of the artifacts or the collection is unknown. All the documentation simply states a general characterization of “deteriorated surface”. Thus, the real problems of the artifacts and the needs of the whole collection in terms of treatment are unknown.
- The storage conditions are partly controlled, meaning that there are heating systems, programmed to work 24 hours. However, when the external temperature is low, something frequent during winter and spring months, these systems cannot function, resulting in an indoor environment with wide temperature and RH fluctuations.

A classification of the artifacts based on their technological characteristics and condition was conducted by visual examination, using Burt frequency tables for this project, and around 873 artifacts were selected for further scientific examination.

This process was not always easy to apply, since the details of the construction of an object are not always immediately obvious: surface features and decoration may be concealed under layers of corrosion, joins might be internal and sometimes the signs of casting or working can only be found within the metal itself [1].

The iron artifacts from the collection exhibit clear signs of active corrosion (e.g., presence of akageneite and detachment of pieces known as spalling). However, the amount of metal remaining is difficult to ascertain as well as the initial shape or form of the artifact.

Artifacts made by copper alloys are both cast and/or hammered, but sometimes it is difficult to distinguish between these two manufacturing techniques by visual inspection alone, especially for

thin and small objects. Also, some of the artifacts exhibit surface decoration and features, not always visible due to the presence of thick corrosion layers. Finally, it can be difficult by visual inspection alone to determine the actual condition of the objects, when the extent of internal cracks and fissures are hidden underneath the corrosion products.

In the case of the metals collection of Ancient Messene, the artifacts cannot be transferred outside of the museum due to the legislation for antiquities in Greece. Thus, any scientific examination must be undertaken in-situ using in our case a portable X-ray radiography system (including a portable film processor).

Visual examination of objects is not always easy to apply, since the details of the construction of an object are not always immediately obvious: surface features and decoration may be concealed under layers of corrosion, joins might be internal and sometimes the signs of casting or working can only be found within the metal itself [1]. X-ray radiography is a non-destructive technique, which is often used to reveal these hidden clues for the method of manufacture, decorative detail, as well as the overall condition of the artifacts [1]. As an examination tool for metal artifacts, X-ray radiography contributes to our knowledge for the society that produced the artifacts and to our broader understanding of the history of technology [1].

The application of X-ray Radiography for the examination of cultural heritage objects is a routine and common practice world-wide. However, our literature survey, using the BCIN database ([www.bcin.ca](http://www.bcin.ca)) revealed that the application of portable X-radiography systems is not common. For example, only five references to the use of such a technique were found [give all five], but none of them referred to the examination of metal artifacts [2-6] This paper outlines the application of such a system to study a collection of metal artifacts housed in a museum.

## 2. HISTORICAL AND ARCHAEOLOGICAL INFORMATION

### 2.1 Historical preface

The archaeological site of Messene is located at the foot of Mt. Ithome, under the modern village of Ancient Messene of the prefecture of Messenia in Peloponnesus. (photo 1) [7]

All the public and sacred buildings and the preserved fortifications have been excavated during four excavation periods, covering an interval of 174 years (1831-today). From 1986 till now, the excavations are headed by P. Themelis.

Ancient Messene, the new capital of the free and independent Messenia, was founded in 369 B.C. by general Epameinondas from Thebes.

All the public and sacred buildings were abandoned c. 360-70 AD, due to the economic decline of the Roman Empire, the invasions of barbaric raids, and the earthquakes. Some of them were used during the Early Christian period and after a certain period of abandonment were inhabited again from the 10<sup>th</sup> c. A.D. [7]

### 2.2. Archaeological and excavation context

The city of Ancient Messene was protected from strong fortification walls, covering an area of 9.5km, built with large stone blocks up to the ramparts. [8]

The first monument one encounters on the way from the Museum to the archaeological site is the **Theatre**, a particular monument, anticipating the gigantic theatres and amphitheatres of the Roman period. To the east of the Theatre is situated the **Agora** of Messene.

The **Asklepieion complex** was the centre of the public life operating side by side with the nearby Agora. (photo 1)

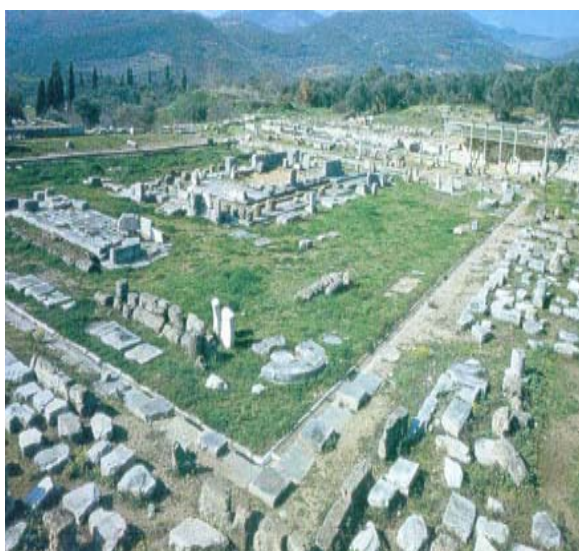

**Photo 1:** View of the Asklepeion from NE

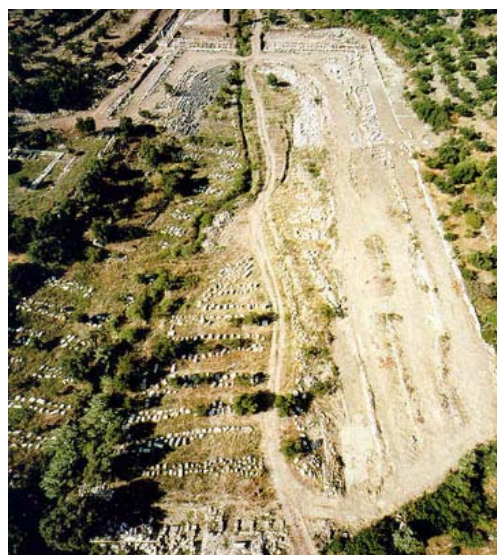

**Photo 2:** View of the Stadium from SE

The **Stadium** and the **Gymnasium** to the south of the Hierothysion are among the most impressive and well-preserved building complexes of the site. (photo 2)

### 3. THE METALS COLLECTION

The metals collection includes artifacts manufactured from gold, silver, lead, iron and copper alloys, as well as a rich collection of coins. The approximate number of metal artifacts are estimated around 5,000 and 13,000 are coins. Tables 1 and 2 provide a description of the types of copper and iron artifacts studied for this project respectively. However, new artifacts are discovered yearly as excavations continue to take place. The nature of the collection is relevant to the city's public and private activities and mainly consists of objects of every day use (utilitarian and decorative), serving the needs and the customs of the city's society.

**Table1:** A description of the types of copper alloy artifacts found in the museum of ancient Messene

<b>TOOLS- INSTRUMENTS</b>	<i>Scrapers, spatulas, chisels, medical tools, spades, needles, tongs, quill, ax, hook</i>
<b>ACCESSORIES OF DOORS &amp; FURNITURE</b>	<i>Simple nails, decorative nails, cringles, parts of locks, keys</i>
<b>DECORATIVE ARTIFACTS</b>	<i>Mirrors, buckles, rings, pins, bracelets, earrings, necklace</i>
<b>VESSELS</b>	<i>Small vessels, rims, handles, bases, covers, decorative elements</i>
<b>FIGURINES- STATUETTES</b>	<i>Animal &amp; Human</i>
<b>WEAPONS</b>	<i>Spear &amp; arrow shafts, savrotiras, shields</i>

**Table 2:** A description of the types of wrought iron artifacts found in the museum of ancient Messene.

<b>WEAPONS</b>	<i>Shaft &amp; arrow peaks, savrotiras, daggers, butcher Knives</i>
<b>TOOLS-INSTRUMENTS</b>	<i>Scrapers, scissors, spatulas, spades,</i>

	<i>cradles, chisels, knife and carving blades, hooks, needles, tongs</i>
<b>ACCESSORIES OF DOORS &amp; FURNITURE</b>	<i>Simple &amp; decorative nails, cringles, parts of locks, keys, sheathing foils</i>

Most of the artifacts were excavated during the last excavation period, which started in 1986 under the supervision of P. Themelis and still continues today. The artifacts come from all the excavated complexes, which form the public sector of the city, as well as from grave monuments of wealthy Messenians.

Previous analysis of soil samples from the archaeological site, with the application of Atomic Absorption Spectroscopy (A-A-S), led to the characterization of the burial environment as a sloughy sand soil with a pH ~ 7.4, and a concentration of SiO<sub>2</sub>, Al<sub>2</sub>O<sub>3</sub>, and CaO ranging in weight percentage between 60.9-68.5, 9.3-11.2%, and 1.4-7.0% respectively [9].

The archaeologists register all the excavated objects in documentation cards and book catalogues, which include general information for each artifact (excavation context, excavation date, brief description and dimensions).

Until last year all the metal artifacts were kept in wooden boxes, not separated, in storage rooms with uncontrolled conditions in terms of relative humidity (RH) and temperature.

Last year the archaeologists moved the artifacts into one of the upper storage rooms (see photos 3 and 4), where heating systems exist. They had separated the metals and placed each artifact or a group of similar artifacts in polyethylene bags with zip closing, with an indication of the excavation context and date written in paper. However, the bags were placed again in wooden boxes and each box indicates the excavation context, from where the stored artifacts were found.



**Photo 3:** View of storage room



**Photo 4:** View of storage room

Furthermore, most of the funds are spent in restoration projects of the excavated monuments. Few, if any, metal artifacts undergo treatment. Also, there is a lack of know-how in the proper care of such metals collections. For example, most of the iron artifacts were excavated from wet soil, and were left to dry immediately after excavation.

#### **4. USE OF A PORTABLE X-RAY RADIOGRAPHY SYSTEM FOR THE EXAMINATION OF THE METALS COLLECTION IN ANCIENT MESSENE.**

The curator (archaeologist) of a museum that houses a major metals collection typically confronts the following problems:

1. Difficulty in determining the value of the collection in terms of ancient metallurgical techniques by visual inspection alone.
2. Difficulty in understanding the actual condition of the artifacts, such as the amount of metal remaining, the presence of internal cracks and fissures, and the extent of corrosion layers.
3. Difficulty in sending out objects for any type of scientific examination without official permission. The current Greek legislation for antiquities does not easily permit the transportation of an object or a collection to a scientific lab for analyses, and the sampling from artifacts is also controlled.

Thus, the only solution is to provide the application of X-Ray radiography *in-situ* to answer the relevant problems. Also, such an examination helps the curator to appreciate at a first level the value of the whole collection in terms of technology and the condition of the objects, since more objects may be analyzed in-house than if they were removed from the museum.

The present situation of the metals collection in Ancient Messene is typical for most museums in Greece, so that a decision was made to obtain a portable X-ray radiography system, in order to be able to conduct *in-situ* analysis of the metals collection. We also investigated the option of hiring someone to bring in their own system and carry out the work *in-situ*, but their quote came out to the same as purchasing our own equipment. However, our decision required the cooperation with an experienced and certified radiographer/radiologist, which worked for the TEI of Athens and is an author of this paper. Furthermore, we spent time conducting market research to select a used system that would suit our purposes and be relatively inexpensive.

The system chosen is as follows:

1. A second-hand Military control Unit and Tube Transformer Head, X-Ray Apparatus 15 m.A., Mobile-Portable, Stock No. -6-013-680, manufactured by Picker X-Ray Corp., Waite MFG. DIV., Cleveland, Ohio, U.S.A.
2. A portable film processor Curix 60/CP1000, Type 9462, 230V/50/60Hz, manufactured by Agfa-Gevaert N.V., Belgium.

The mobile tubestand (1344-D) is packed within a single chest (see Figure1) and contains the following items as described in the manual [10]:

- a. Mobile base assembly with casters and wheels including tool and spare parts compartment.
- b. Lower mast section complete with vertical carriage.
- c. Upper mast section.
- d. Horizontal tube arm assembly, complete with latch.
- e. Control mounting bracket.
- f. Crank for actuating vertical carriage.
- g. Instruction manual.
- h. Tools and spare parts.

The X-Ray source (see Figures 2a and b) is also packed within a single chest, including the following items[10,11]:

- a. A radiation cone.
- b. A shockproof head.
- c. A hand-timer.
- d. A head retainer catch.
- e. F-12 control unit.

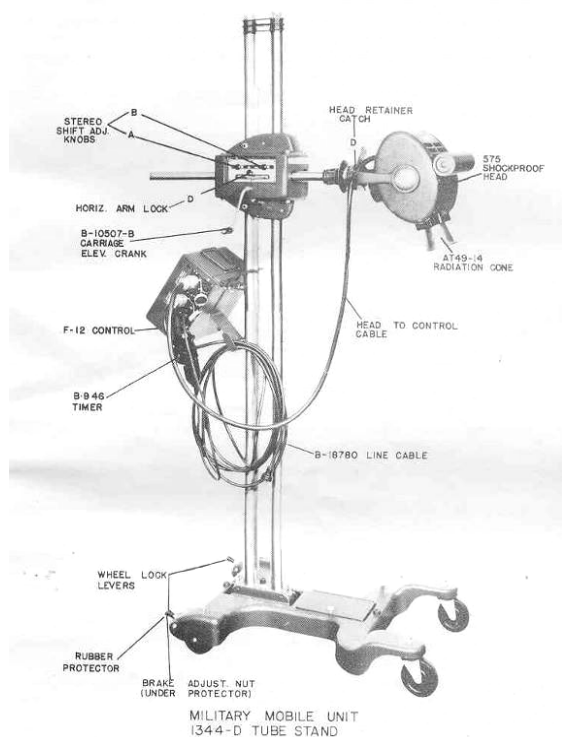

**Fig. 1:** Mobile tubestand

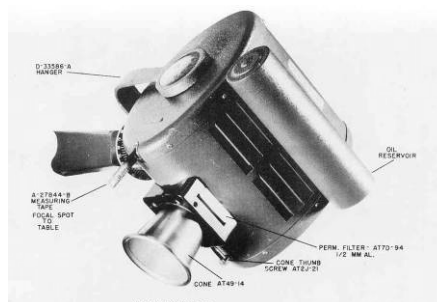

**Fig.2a:** Shockproof head and radiation cone.  
**Fig.2b:** F-12 control unit

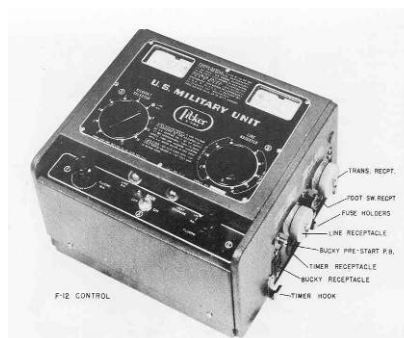

This system was purchased for 1700 Euros. The system could be carried and assembled *in-situ* easy and fast, following the instructions manual and with the help of a certified radiologist.

The Curix 60 is a film processor developed and manufactured by Agfa (see Figure 3) [12]. It is designed for darkroom installation and has been engineered according to the very latest principles. Based on a proven concept, the system has the following advantages:

1. Top quality
  - rugged racks with chemical-resistant transport rollers.
  - reliable tank heating.
  - infrared dryer (drying system of maximum possible efficiency).
  - film surface scanning.
2. Low operating costs
  - easy installation, switched outlet connection, minimum amount of space.
  - fully automatic economy circuit.
3. Simplicity of use
  - switching on by pressing a button; film returned on top.
4. Ease of servicing and environmental protection.
  - separable racks easy to remove and clean.
  - low-noise operation with low heating emission.

Functional diagram

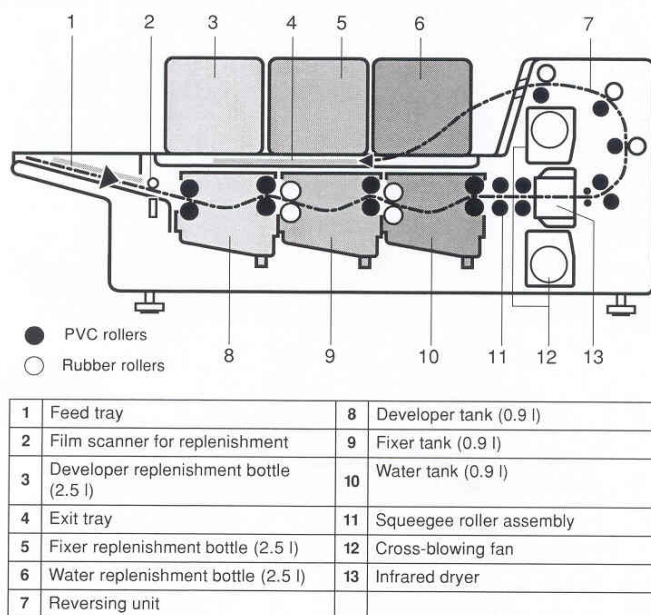

**Fig.3:** Functional diagram of the portable Curix 60 film processor.

Exposed film is inserted directly into the feed slot at the left side of the processor. The film passes the film scanner regulating the replenishment and dryer systems, and then passes through the developer, the fixer and the wash-water tanks. After drying, the film leaves the dryer section and is deposited on the exit tray [6].

This system was purchased for 4.700 euros and was installed easily in a bathroom, situated next to the storage room where the collection is kept. The bathroom was converted into a dark room for the present situation (see Photos 5 and 6). The total cost for the purchase of 100 radiographic films 24X30 NIF, 100 radiographic films 35X35 NIF, 12 bottles of developer liquid, 18 bottles of fixer liquid and two radiographic cassettes was 712 Euros.



**Photo 5:** The portable film processor



**Photo 6:** The portable X-ray radiographer



## 5. SAFETY RULES

According to the manufacturer's manual, while operating the portable radiography system, all the necessary precautions must be considered, following the recommendations of the National Bureau of Standards and of the International Roentgen Ray Committee on X-Ray protection.

After personal communication with Dr. Th. Panou, certified radiologist, it was established that the portable X-ray radiography system could be used in areas that are not armoured for radiation. For this reason, the application of specific rules is obligatory, in order to achieve protection against radiation and make the system's operation safe:

1. The system must be operated only by a certified user namely a radiologist or a technician radiologist.
2. The system must be placed inside a room of the museum, surrounded by walls.
3. The cable for the exposition switch must be at least 10 meters long.
4. The operator is obliged to use a smock sheathed with lead.
5. Care should be taken, so that no people are present in rooms under the floor, when the portable radiography system is in operation.

Finally, we should point out that in the application of a portable radiography system the number of radiographs is much smaller than in a X-ray radiographic lab and thus exposition parameters –kV, mAs, sec- are particularly low.

## 6. METHODOLOGY

Over 1000 objects of different shapes and dimensions were examined in two days using the X-ray Radiographic system. This required operating the system 8 hours each day, using 85 radiographic films (dimensions 24X30cm and 35X35cm), 8 bottles of developer liquid, and 5 bottles of fixer liquid. The general operating parameters involved are the following:

- Distance of the lamp from the radiographic plate: 75cm
- Correction of voltage of the local line at 70kV.

Two radiographic plaques, dimensions 24X30cm and 35X35cm, were used.

Objects with big dimensions were placed separately in one single plaque, while small objects of the same type were placed together, as long as they did not present variations in thickness more than 1cm.

The objects were placed together with their paper tabs, indicating the excavation context and the registration number, and were photographed with a digital camera, before being X-rayed. As a result, a digital record was created in order to distinguish the objects in each radiographic film (see Photos 7, 8 and 9).



**Photo 7:** Radiography plaque 35X35 with nails. **Photo8:** Radiography plaque with mirror. **Photo 9:** Radiography plaque 24X30 with knives.

## 7. RESULTS-DISCUSSION

The application of X-ray radiography in the case of the metals collection of Ancient Messene revealed useful information concerning the manufacturing technology and the condition of the artifacts.

The following characteristic examples show the utility and the feasibility of the technique.

In photos 10-21, the mirrors are presented. The study of the radiographs led to the following observations:

1. All the mirrors were made by casting. One could observe the characteristic porosity, the thickness variations, and a coarse granular appearance or texture that is usually present for cast objects.
2. The light areas are usually indicative of the presence of lead.
3. The dark areas show where the metal is thinner.
4. The extent and the thickness of cracks and fissures are depicted.
5. The techniques used for surface decoration are shown.



**Photo 10:** Circular mirror with raised rims, decorated with concentric circles (3rdc. B.C.)

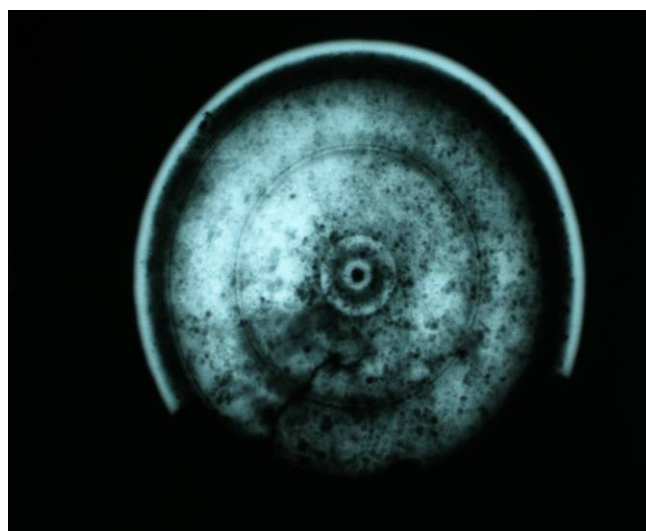

**Photo 11:** X-radiography (65kV, 10mAs, 1 sec). The radiograph depicts a coarse cast structure. The light areas are probably lead.



**Photo 12:** Simple circular mirror, decorated with concentric circles and an embossed spiral motive (3rdc. B.C.)

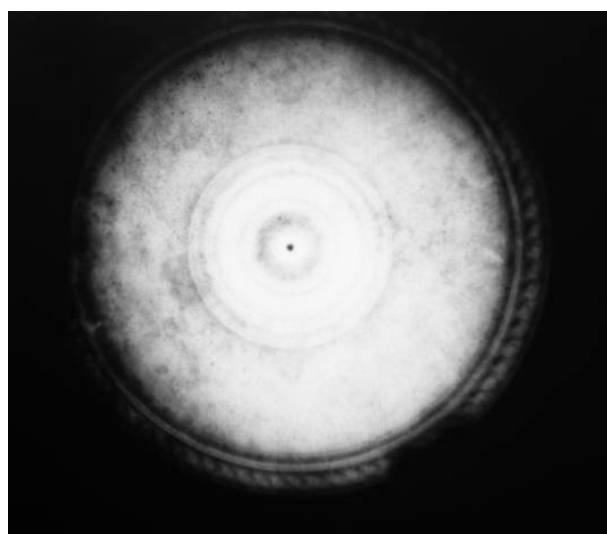

**Photo 13:** X-Radiography (65kV, 10mAs, 1 sec). The radiograph depicts a coarse cast structure and the embossed decoration.



**Photo 14:** Circular mirror with raised rims, decorated with concentric circles (3<sup>rd</sup> c. B.C.)

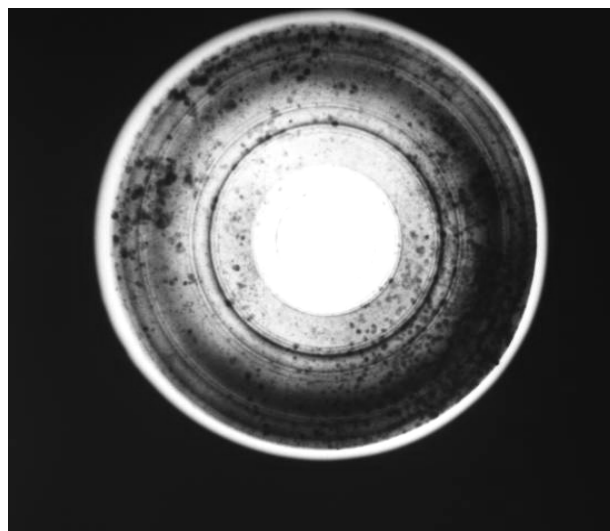

**Photo 15:** X-Radiography (60kV, 15mAs, 1.5sec). The radiograph depicts a cast coarse structure. The dark areas show where the metal is thinner.



**Photo 16:** Simple circular mirror (2<sup>nd</sup> c. B.C.)

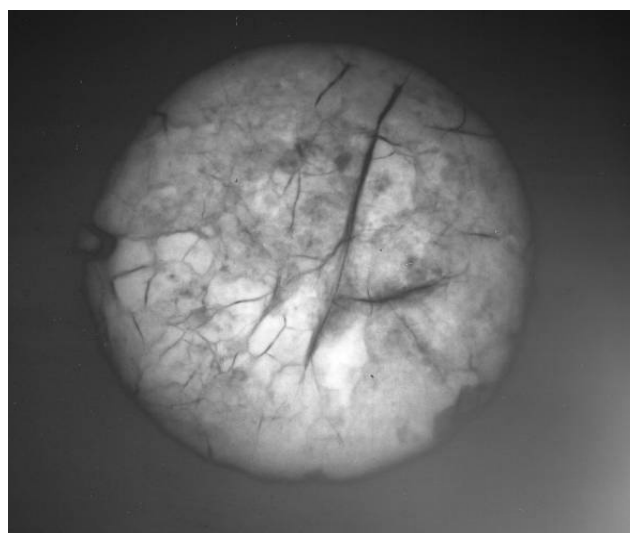

**Photo 17:** X-Radiography (85kV, 30mAs, 3sec). The radiograph depicts the cast structure, the extent and thickness of cracks and fissures. The light areas are probably lead.



**Photo 18:** Rectangular mirror, tin-plated.  
(2<sup>nd</sup> c. B.C.)

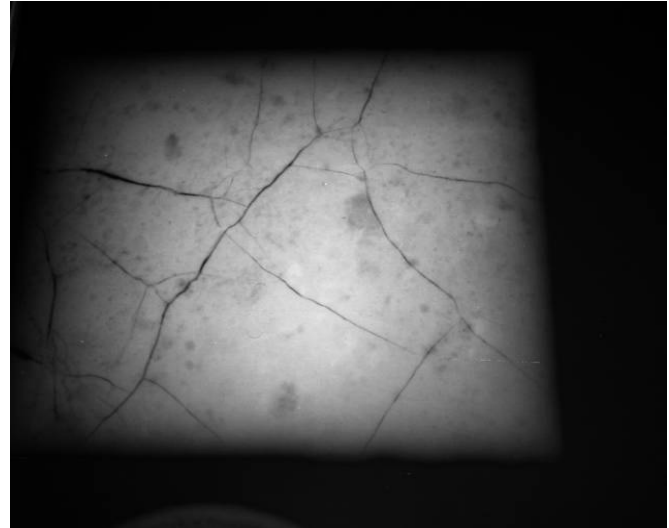

**Photo 19:** X-Radiography (85kV, 30mAs, 3sec). The radiograph depicts the cast structure, the extent and thickness of cracks and fissures. The light areas are probably lead.



**Photo 20:** Simple circular mirror, probably tin-plated (2<sup>nd</sup> c. B.C)

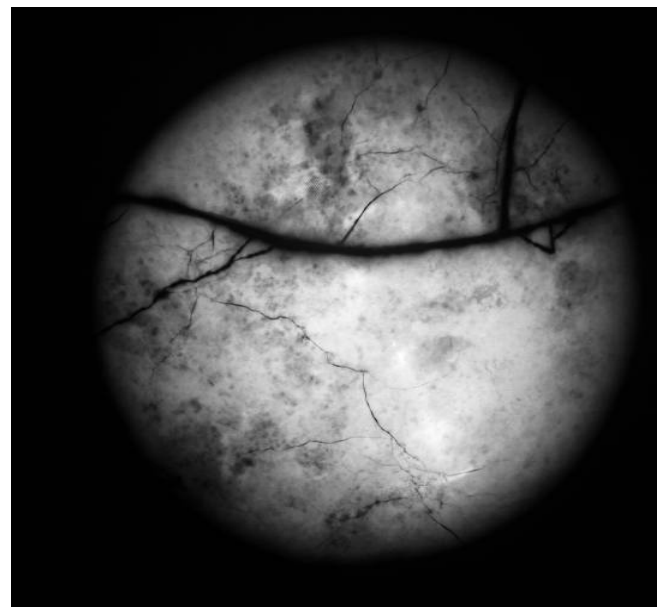

**Photo 21:** X-Radiography (80kV, 25mAs, 2.5sec). The radiograph depicts the cast structure, the extent and thickness of cracks and fissures. The light areas are probably lead. The dark areas show where the metal is thinner.



Another example of the utility of the technique is that of a copper alloy shield dated at the end of 4<sup>th</sup>-beginning of 3<sup>rd</sup> c. B.C. (see Photos 22-25). The shield is covered with soil deposits and corrosion products. The X-radiography revealed the surface inscription and decoration and the manufacturing technique applied, as well as the condition of the shield -cracks, fissures and amount of metal remaining.

**Photo 22:** Shield from copper alloy  
**Photo 23:** X-Radiography (65kV, 10mAs, 1sec). The

radiograph depicts the condition of the object: white areas

indicate presence of metal core, grey areas indicate

corrosion products and black areas absence of metal.

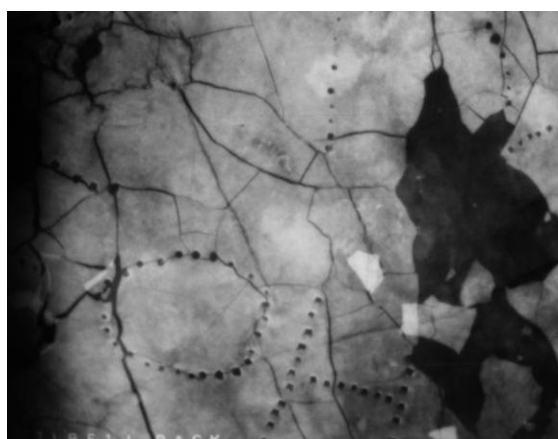
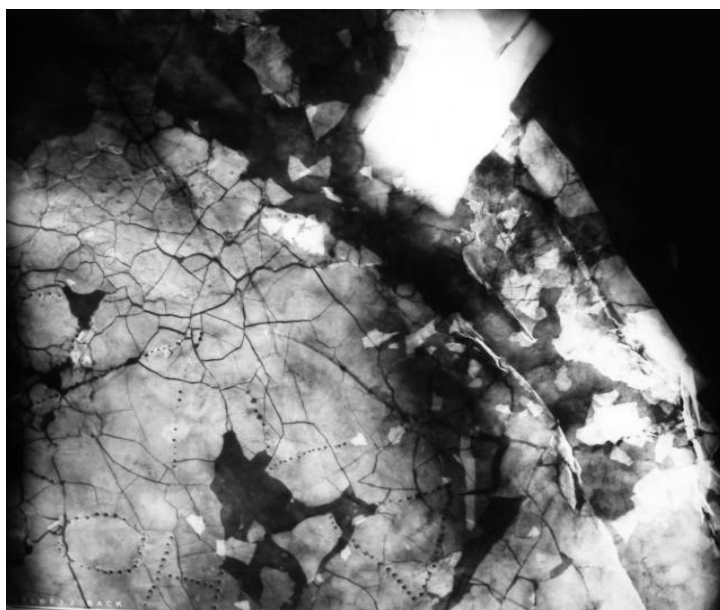

**Photo 24:** X-Radiography of punched inscription (65kV, 10mAs, 1sec)

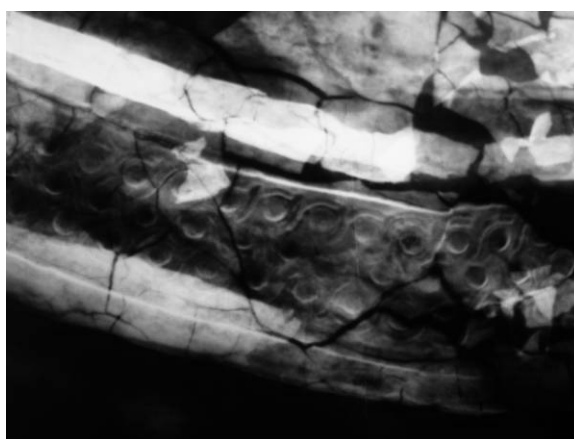

**Photo 25:** X-Radiography of hammered decoration depicting a floral motive (65kV, 10mAs, 1sec).

The radiographs of iron artifacts revealed different information, as one could see through the examples of scissors (see Photos 26-27), knife blades (see Photos 28-29) and scrapers (see Photos 30-31).

1. All iron artifacts are wrought iron.
2. The radiographs revealed the initial shape and form of the artifacts.

- The condition of the artifacts is clearly shown, since one could observe the amount of metal remaining, as well as the areas where no metal core is retained and the artifacts are mineralized.



**Photo 26:** Iron scissors

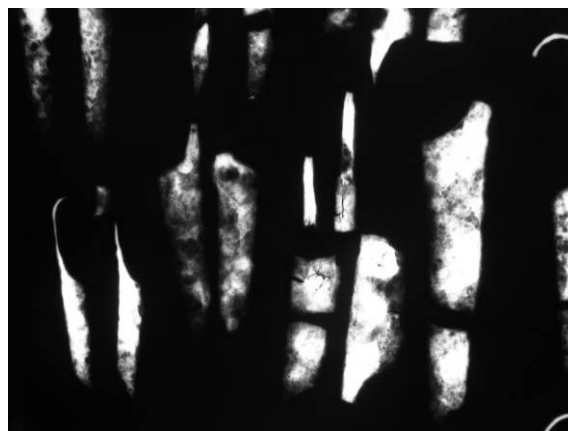

**Photo 27:** X-Radiography (55kV, 10mAs, 1sec). White areas indicate presence of metal core, grey areas indicate corrosion products and black areas absence of metal.



**Photo 28:** Iron knife blades



**Photo 29:** X-Radiography (55kV, 10mAs, 1sec) White areas indicate presence of metal core, grey areas indicate corrosion products and black areas absence of metal.



**Photo 30:** Scraper

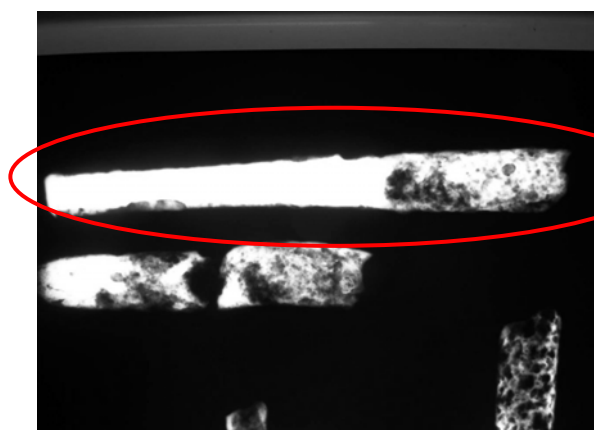

**Photo 31:** X-Radiography (55kV, 10mAs, 1sec) White areas indicate presence of metal core, grey

areas indicate corrosion products and black areas  
absence of metal.

## 8. CONCLUSIONS

- Portable X-ray radiography is a useful and easy technique to apply *in-situ*, overcoming the need of removing the artifacts from their storage or display room to a location outside the museum facilities. Thus, an entire collection can be examined, and at the same time the objects are safe.
- With the purchase of a portable film processor one could develop the radiographs fast and easy *in-situ*, so as to better select the operating parameters of the system and achieve better results.
- The consumables needed for the operation of the system were relatively low.
- The X-ray radiography gives valuable information for the technology and the condition of the artifacts.
- The conservator(s) can make the necessary decisions on how to clean and/or stabilize the metal artifacts.
- With proper training conservators can learn to use such a system.

## Acknowledgements:

The authors would like to thank Amalia Siatou and Stavroula Poulimenea, professional conservators-restorers, for their assistance during the X-raying of the metals collection of Ancient Messene. We also gratefully acknowledge the funding from the European Commission to carry out this work.

## REFERENCES

- [1] Lang, J, Middleton, A., “*Radiography of Cultural Material*”, Butterworth Heinemann, England,1997.
- [2] David, A. R., Tapp, E., “*Evidence embalmed: modern medicine and the mummies of Ancient Egypt*”, Manchester and Dover: Manchester University Press, 1984.
- [3] Paderni L., “*I raggi x nell’arte*” in Conferenza internazionale su le prove non-distruttive nella conservazione delle opera d’arte, Roma, 27-29 Ottobre 1983. International conference on non-destructive testing in conservation of works of art, Proceedings. Roma: Associazione italiana prove non-distruttive / icr, 1983, pp.21.1-21.14
- [4] Hart, D., “*X-ray inspection of historic structures: an aid to dating and structural analyses*” in Technology & Conseravtion, Vol. 77, 1977, p. 10-27.
- [5] Marconi, B., “*X-raying pictures: new Polish devices and methods*”, in Ochrona zabytków, Vol.1, 1949, pp.25-30.
- [6] Owen, G., “*Use of a portable x-ray machine in archaeological fieldwork*”, Cambridge Archaeological Journal, Vol. 3 No.1,1993, pp.134-136.
- [7] Themelis, P. “*The Ancient Messene*”, Ministry of Culture, T.A.P.A editions, Athens 2002.
- [8] Themelis, P., “*Ancient Messene. Site and Monuments*”, Special edition of the region of Peloponnese, 1998.
- [9] Giannoulaki M., and Poulimenea S., “*Mahaon. Hermes. Presentation, research and discussion for the conservation/restoration of two marble sculptures from Ancient Messene*”, Diploma Thesis, Dept. of Conservation of Antiquities & Works of Art, T.E.I. of Athens, 2000, (in Greek).

- [10] Anon., Instructions for Military Tubestand X-Ray Apparatus, Mobile-Portable, Stock No. -6-169-250, Picker X-Ray Corp., Waite MFG. DIV., Cleveland, Ohio, 1952.
- [11] Instruction Manual for Military Control Unit and Tube Transformer Head, X-Ray Apparatus 15 M.A., Stock No. 6-013-680, by Picker X-Ray Corp., Waite MFG. DIV., Ohio, 1952.
- [12] Curix 60, Reference Manual, Agfa-Gevaert N.V., Belgium 2000.